

DIMENSIONS:

17.52"(DIAMETER) x 7.47"(H)

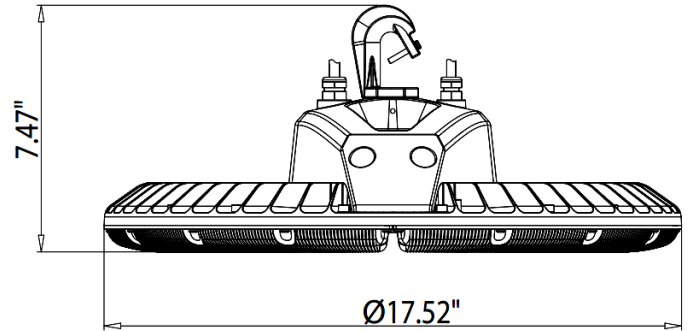

USHB-200W-50K
USHB-200W-40K

LED SATURN HIGH BAY

Ideal for indoor parking lots, commercial buildings, schools, warehouse, retail centers, apartment, complexes,

ELECTRICAL SPECIFICATIONS:

- Voltage: 120~277VAC, 50/60 Hz
- Wattage: 200W
- Power factor: >0.90
- Total Harmonic Distortion (THD): < 20%
- Efficacy: 130LM/W

HOUSING SPECIFICATIONS:

- Housing: Aluminum heat sink, White finish
- Aluminum LED Board: High conductive, waterproof, aging resistant, salt mist resistance, long-life
- Cord type: 6' SJTW 18/3 AWG cable
- Operating temperature: -4°F to 122°F
- IP Rating: IP66, Suitable for Wet Locations

CERTIFICATIONS: UL, DLC, NSF



MODEL	WATTS	VOLTAGE	LUMENS	COLOR TEMP
USHB-200W-50K	200W	120~277VAC	26000LM	5000K
USHB-200W-40K	200W	120~277VAC	26000LM	4000K

LIGHTING SPECIFICATIONS:

- Dimming: 0~10V Dimming
- Total lumens: 26000LM
- Color temperature: 5000K/4000K
- CRI: >80
- Beam Angle: 110°

WARRANTY: 5 years

